

## TAMPING RAMMER



TAMPING RAMMER,  
Four-cycle Petrol Engine,285mm foot

Model:MTX-60,MTX-70,MTX-80,MTX-90

Product nos(standard export model only):

MTX-60:51087

MTX-70:51233

MTX-80:51265

MTX-90:51275

### SUITABLE APPLICATION

Worldwide contractor acceptance has led us to become one of the world's largest rammer producers with constant adoption of advance technologies, unmatched unit balance, safety and functionality.  
With the debut of the MTX series rammer we open another chapter of accumulative innovation and success.

### FEATURES and BENEFITS

- \*Outstanding body balance maximizes work efficiency and minimizes operator's fatigue.
- \*Ergonomic, streamlined, eye appealing design.
- \*Meticulous attention to safety and operator's.
- \*Fewer frequent maintenance cycles in routine operation.

Hour & Tacho Meter



Throttle lever with a kill switch interlocking with fuel cutoff mechanism.





Moving image of MTX Rammer

\*Latest Adobe Flash Player are required for playing above the movie. If you don't have it, please download and install from the links below.



**SUITABLE APPLICATION**

(Features and specifications are subject to change without notification.)

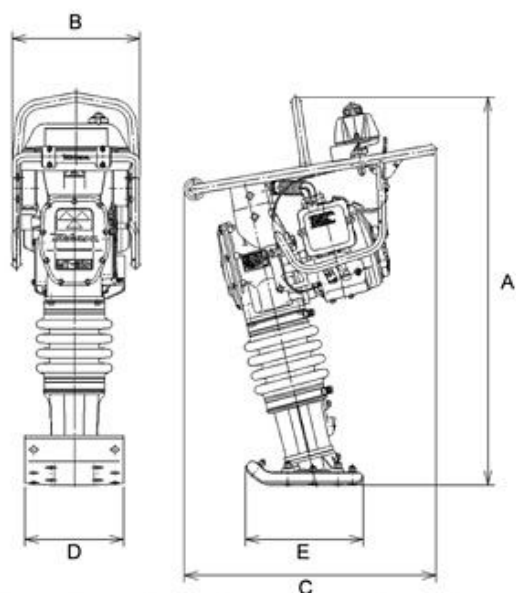

	MODEL	A(HEIGHT)	B(WIDTH)	C(LENGTH)	D	E
Dimensions (L x W X H)	MTX-60	985	350	713	265	340
	MTX-70	1000	350	788	285	340
	MTX-80	1000	365	788	285	340
	MTX-90	1000	365	788	285	340
MODEL	MTX-60	MTX-70	MTX-80	MTX-90		
Operating Weight	<b>64kg</b>	<b>75kg</b>	<b>83kg</b>	<b>89kg</b>		
Jumping Stroke	50-80 mm					
Impact Force (max.)	13.6kN (1,390kgf)	14.9kN (1,520kgf)	15.6kN (1,590kgf)	16.5kN (1,680kgf)		
Impact Number per min.	644-695		642-679	660 -698		
Fuel Capacity	2.0 liters	3.0 liters				

Engine Type	Air-cooled, 4 cycle, Petrol(Gasoline)	
Model	Honda GX100	Robin EH12-2D
Max. output	2.1 kW (2.9PS)	2.6 kW (3.5PS)

Impact Force is measured at Mikasa in comply with CIMA-LEMB  
Weight is measured in comply with Directive EN500-4

---

[TOP](#)

Copyrights 2008 MIKASA SANGYO CO.,LTD All Rights Reserved.